

CONCEPTIONAL DRAWINGS ONLY: DRAWINGS ARE NOT TO SCALE, ALL MEASURES ARE APPROXIMATE & SUBJECT TO ENGINEERING CHANGE

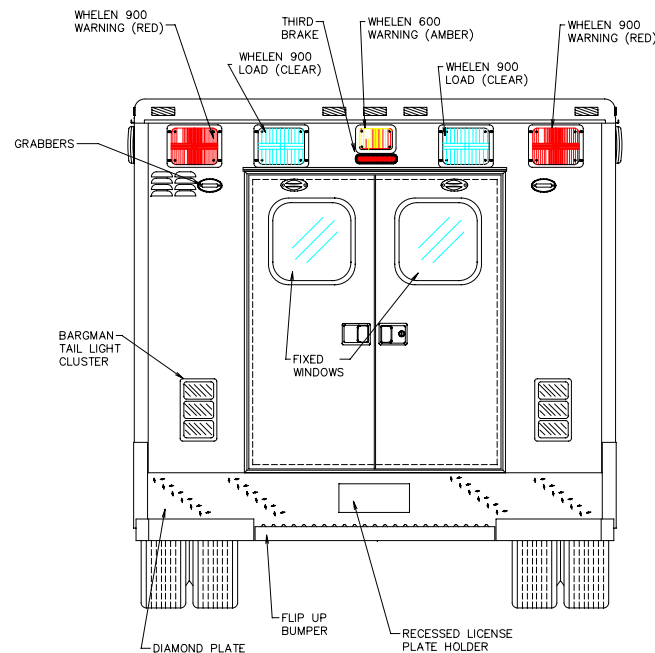

Compartment Dimensions			
Cmpt	Height	Width	Depth
M1	58.5"	19.6"	19.4"
M2	31.5"	22.1"	19.4"
M3	31.5"	32.6"	11"
M5	FULL HEIGHT	10.5"	21"
M6	17.2"	21.8"	19.4"
M7	42.6"	18.3"	N/A
M8	12.1"	18.3"	21.4"
C/S Access	FULL HEIGHT	31"	N/A
Rear Access	56-5/8"	46-3/4"	N/A

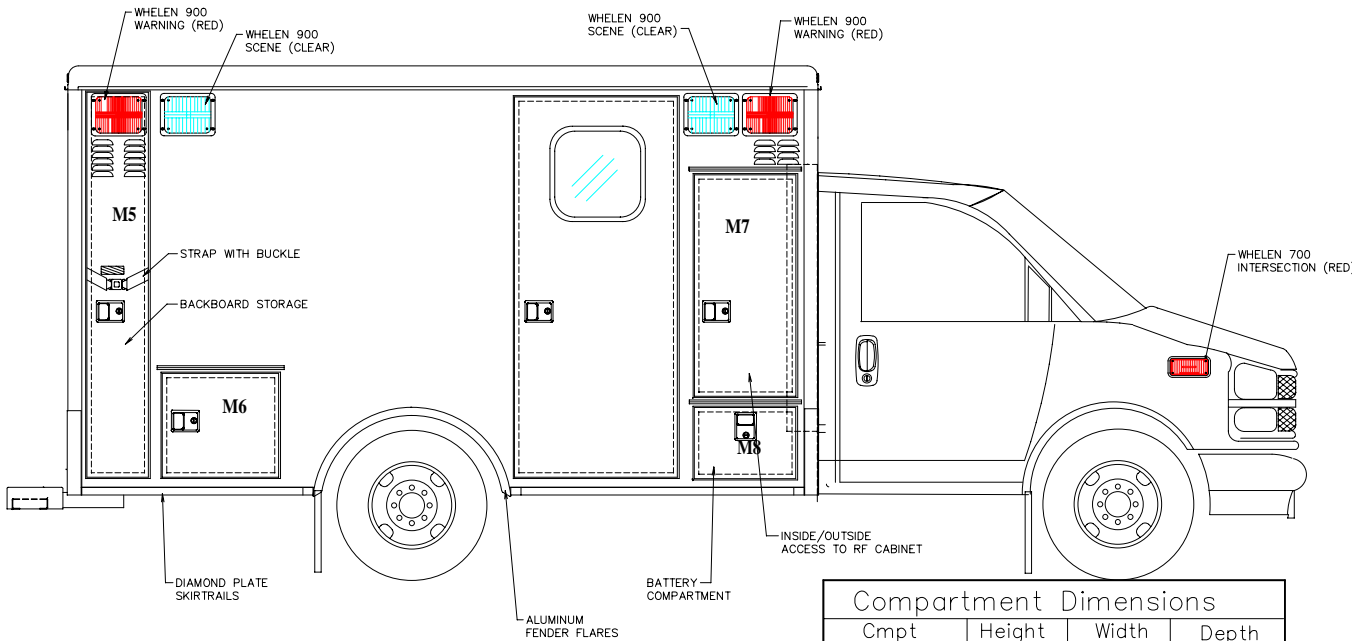
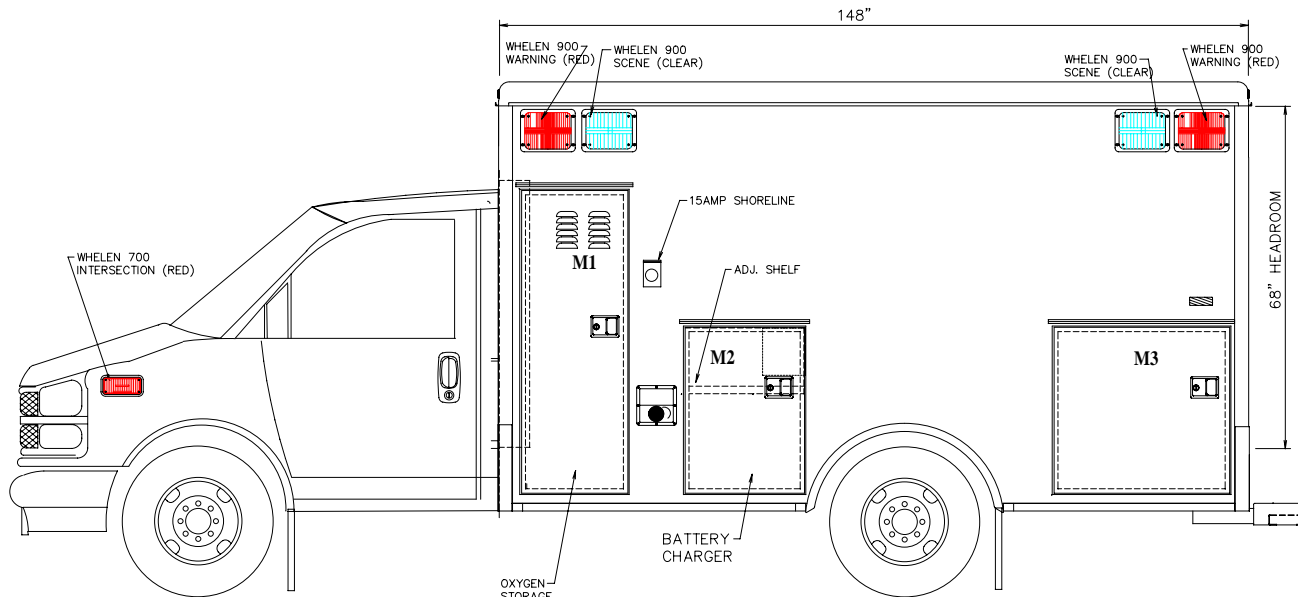
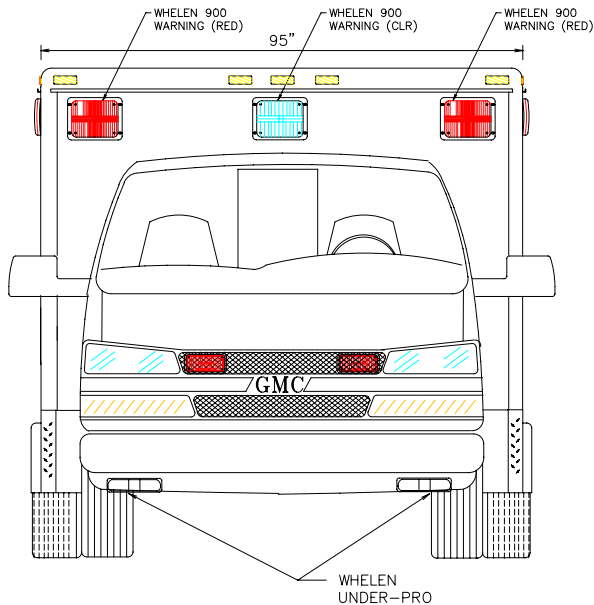

AMERICAN EMERGENCY VEHICLES	
TITLE	Customer:
Type 3, 148", Exterior	
DWG#	REV.#
TRUCK#	
BY:	DATE
BODY #:	

*CONCEPTIONAL DRAWINGS
 * Some shown are optional
 * Due to AEV's ongoing improvements, drawings can change.